

SLiC Push Button Controller

Casambi enabled | SLiC-550E

SLiC-550E



Convert a momentary push-button wall switch into a smart lighting controller

- + Convert each push-button into a smart button for lighting automation scenes of your choosing. Convert a normal on/off push-button to create seasonally adjusted circadian rhythm scenes for healthier lighting, set another push-button to a TV viewing scene, or any scene of your choosing;
- + Perfect for new or retrofit installations – no additional wiring required;
- + Switches may be remotely mounted up to 20m;
- + Simple to install and commission;
- + Compatible with most push button momentary switches or any dry-contact input;
- + Compatible with SLiC Luminaire Controllers and any Classic or Evolution Casambi-enabled product (www.casambi.com);
- + Powered directly from AC supply (< 0.2W) 100-240VAC~ (50/60Hz);
- + Custom antenna design for superior range performance
Range up to 100m in outdoor settings in normal mode;
- + Compatible with new Casambi Long Range modes for even greater range.

The push-button controller is installed behind the wall switch. It is wired to a maximum of four momentary contact switches. Each connected push-button can now be configured with the Casambi App to control individual luminaires, lighting groups or scenes.

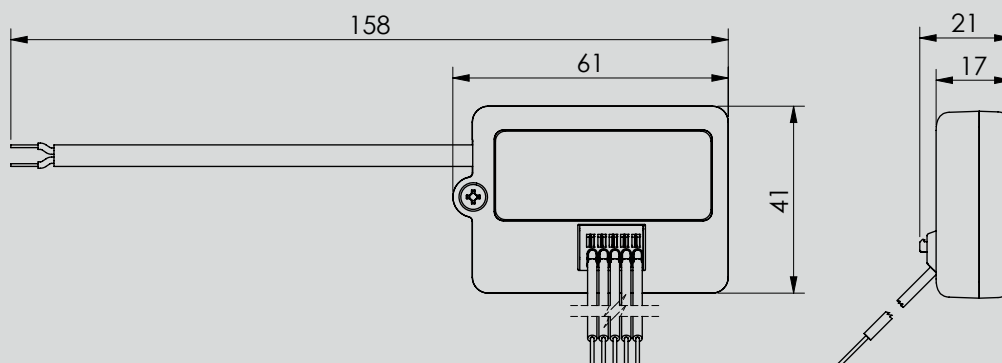



SLiC Push-button Controller

SLiC-550E

Robust mesh network

The Casambi system forms an interconnected Bluetooth mesh – each unit acting independently and as a repeater. The signal distance between each unit is typically 15m but is influenced by surroundings and obstacles. Systems can be easily expanded with any additional Casambi-enabled units.

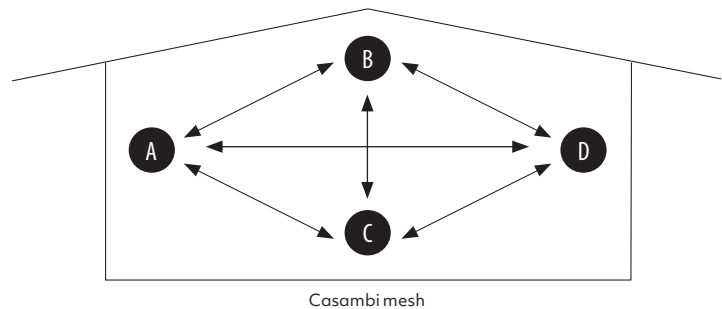

Set-up and operation devices

To commission and operate the Casambi App for the SLiC Push-button Controller, use an iPhone / iPad with iOS 10 and later or Android 4.4 and later. Most Apple and Android phones/tablets are compatible.

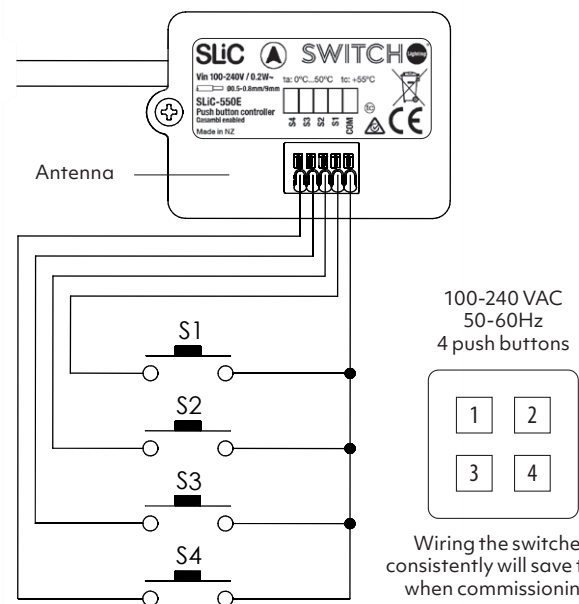

Product information

Parameter	Value
Input Voltage	100-240VAC 50-60 Hz
Power usage	<0.2W
Network Type	Casambi Classic / Evolution
Push-buttons	SLiC-550E 4 max
Bluetooth Radio	2.4-2.48 GHz @ < +4dBm
Ambient temperature	-0 to +50C
IP Rating	IP20
Compliance	EN IEC 55015:2019+A11:2020, EN 61547:2009, EN IEC 61000-3-2:2019+A1:2021, AS CISPR 15:2017, AS CISPR 32:2015, AS/NZS 4268:2017, ETSI EN 300 328 V2.2.2 (2019-07), EN 62479:2010, ETSI EN 301 489-1 V2.2.3 (2019-11), ETSI EN 301 489-17 V3.2.4 (2020-09), IEC 60669-1:2017, IEC 60669-2-1:2002+A1:2008+A2:2015
Connector (push button)	0.4-0.8mm diameter solid wire
Max wire length to momentary switch	20m
Dimensions	61X42X21mm
Weight	25g

Please see www.switch-lighting.co.nz for full specifications, SDoCs and installation instructions.



Warranty
5 years