

D-LIGHTZ *Offset Deep Tilt*



SLDL152T
ULG clear glass
Beam 20° 40° 60°
Task | General lighting



SLDL151T
Prismatic diffuser
Beam 20° 40° 60°
General | Task lighting



SLDL153T
Opaque diffuser
Beam 90°
Wide angle lighting



D-LIGHTZ *Offset Deep Tilt*

- + fully adjustable 360° gimbal
- + 20° offset, 15° tilt
- + suitable for indoor use and exterior under soffits
- + recessed for low glare
- + IP65 front
- + constant current

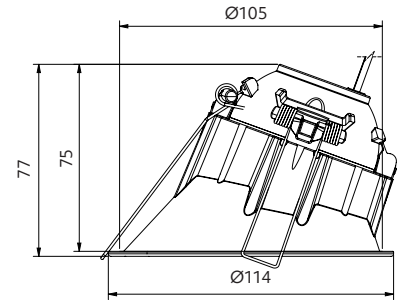

Options

Beam angle

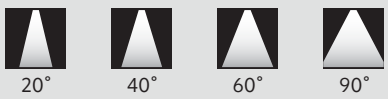

ULG clear glass
Prismatic

Opaque

CCT



CRI

Professional series (P) CRI 90 Art series (A) CRI 97

Trim colour



White

Black

Silver

Driver included – to be specified

Phase cut Dimming

Special request:

- DALI 2 Dimming
- SLiC Casambi Dimming

9-36VDC input options available
Scan the QR code for low voltage driver options



Product information

Table is based on: White, prismatic, 40°, 3000K, CRI 90, phase cut driver
Contact Switch Lighting for data of other variants

Driver (mA)	Power (W)	Delivered lumens (lm)	Insulation coverable		
			NZ	AU	UK/EU
150	6.8	550	IC-F	IC-4	✓
220	9.2	800	IC-F	IC-4	✓
300	13.2	1000	CA135	CA90	✓



*Specification is for ceiling material ≤ 13mm with a phase cut driver.

How to specify D-LIGHTZ Offset Deep Tilt

Please confirm model option availability from our website. **Not every combination is compatible.**

e.g. code = **SLDL151T-40-30-P-W**

Model	Beam	CCT	CRI	Trim Colour	Driver – Phase cut*	Market
SLDL152T = ULG clear glass SLDL151T = Prismatic	20 = 20° 40 = 40° 60 = 60°	27 = 2700K 30 = 3000K 40 = 4000K SD = Sunset Dimming	P = 90 A = 97	W = White B = Black S = Silver	D09 = 150mA (6.8W) = 220mA (9.2W) D12 = 300mA (13.2W)	 = NZ 1 = Aust 2 = UK 3 = EU
SLDL153T = Opaque	90 = 90°				*Check online for driver options.	

Please see www.switch-lighting.co.nz for full specifications, lux levels, SDoCs, ies files and installation instructions.



Warranty
7yr Luminaire
5yr Driver

L70 (60,000 h)

